



MUD VALVE

NEWAY OIL EQUIPMENT



Product Description:

NOE GA and GAM Series mud valves, the premier gate valve in the oil and gas drilling market, are specifically engineered for the rigorous requirements of oilfield applications. Designed for dependable, heavy-duty performance in abrasive service conditions, NOE GA and GAM Series mud valves are commonly selected for a number of oilfield applications, including:

- Drilling standpipe manifold
- Pump manifold block valves
- High-pressure mud mixing lines
- High-pressure drilling system block valves

NOE GA and GAM Series mud valves are available in API working pressures **5000** and **7500** psi (not API monogrammed).

Quality, inspections, and testing

The NOE quality system is based on ISO 9000 and API Spec Q1 requirements and is ISO 9001:2008 certified. NOE monitors all phases of valve production, from material receipt to final inspection, including liaising with third-party inspectors and certifying authorities.

All GA/GAM valves are hydrostatically tested; stem seal, body, and seat are inspected for zero leakage under pressure before being released for shipment. Hydro test specifications are based upon the latest-edition API Spec 6A testing requirements; All GAM valves undergo additional test cycles, including low-pressure seat tests prior to being released for shipment.

■ Hydrostatic shell test—11,250 psi for 3 min. Hydrostatic seat test—7,500 psi for 3 min, each side. Material traceability on body and bonnet.

■ 11,250 psi for 3 min, drop to 0 psi, then 11,250 psi for 15 min. Test is charted. Hydrostatic seat test—7,500 psi for 3 min, drop to 0 psi, 7,500 psi for 15 min, drop to 0 psi, then 300 psi for 5 min, each side. Test is charted. Material traceability on body, bonnet, stem, and bolting. Impact tests at or below -50 degF [-46 degC] on body, bonnet, stem, and bolting. Surface nondestructive examination (NDE) on body, bonnet, and stem.

■ Plus volumetric NDE on body and bonnet.

Seat seal options

■ Buna-N (nitrile) is excellent for petroleum oil and gases, fuel oils, and alcohols from -10 to 200 degF [-23 to 93 degC].

■ FKM is highly resistant to mineral acids and hydrocarbons and is serviceable from -10 to 400 degF [-23 to 204 degC]; not suitable for steam.

■ HNBR is formulated for use with synthetic and oil-based drilling mud service from -20 to 250 degF [-29 to 121 degC].

5000 psi GA Mud Valve Mechanical Features and Benefits

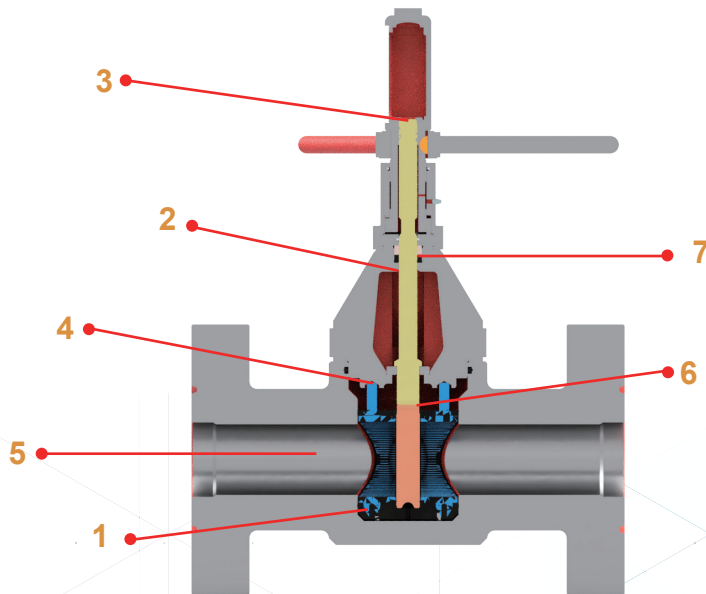

1. Unique, abrasion resistant, one-piece seat design

The seat consists of two identical metal wear rings encapsulated in elastomer to form a cylindrical shape with a gate slot and two round ports. The closed gate bears on the downstream wear ring, while the elastomer provides a drop-tight pressure-responsive seal around the port.

2. In-Line Field Repairability

The bonnet is easily removed for internal parts inspection and/or replacement without removing the valve from the line. This design simplicity permits fast and easy service without the need for special tools.

3. Rising stem design

The mud valve uses a rising stem design that isolates and protects the threads from the line medium. The rising stem also indicates gate position. On 3" (80 mm) and larger valves, a clear position indicator shell allows the operator to easily determine whether the valve is open or closed. The indicator shell also helps to protect the stem threads from the elements.

4. Advantage of one-piece seat design

The cylindrical seat assembly fits into the machined body cavity and is expanded outward toward the valve ports by the bonnet and spread ring in the bottom of the seat. The expansion occurs when the bonnet is tightened onto the body while engaging the seat pin extensions from both wear rings. The spread ring ensures the seat elastomer presses uniformly against the body bore. This design ensures the seat seals tight against the body and around each valve port. This design has proven to be effective even if the gate and seat ring become scored or abraded during service. When it comes time for maintenance, the seat's single-piece design makes it easy to pull out of the body for replacement.

5. Flow cleansed design

The body cavity area is designed to allow continuous flushing by the fluid flow. This action prevents the valve from sanding up, even in standpipe installations.

6. "T" slot stem design

A slab gate with a "T" slot stem connection allows the gate to float to the seat, providing a tighter pressure-responsive seal.

7. Replaceable stem packing

The stem packing can be replaced without removing the bonnet from the valve, 3" to 4" (80 mm to 100 mm), saving time when this maintenance may be required.

Note: line and valve pressure must be relieved before performing this maintenance.

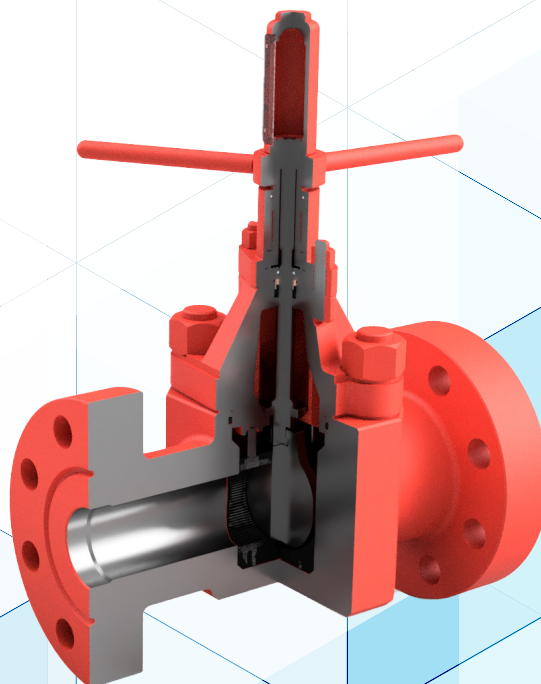

7500 psi GAM Mud Valve Mechanical Features and Benefits

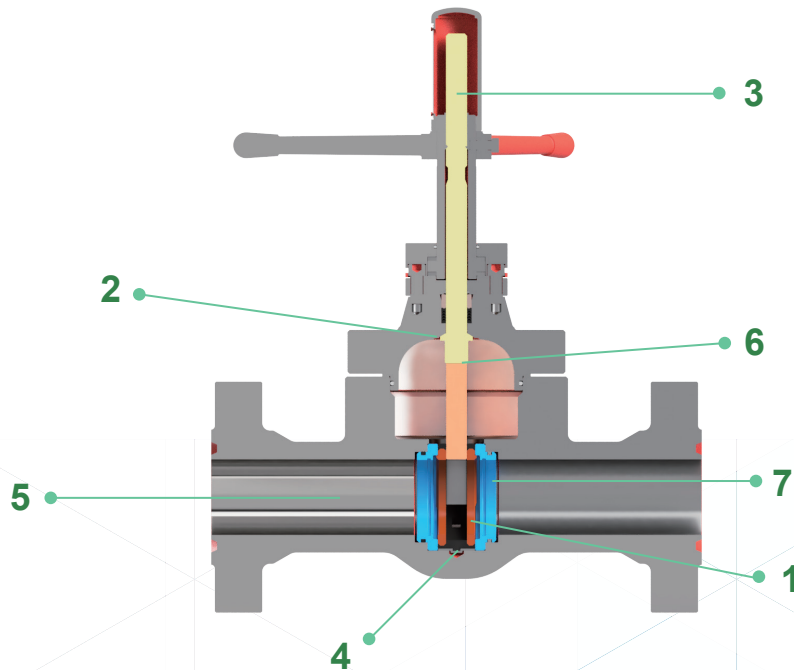

1. Unique, abrasion resistant, one-piece seat design

The seat assembly consists of two stainless steel insert/support rings to which a resilient elastomer is permanently bonded. The elastomer provides tight shutoff after long use in abrasive service. The stainless steel rings are corrosion and erosion resistant. The one-piece design makes field replacement easier.

2. In-Line Field Repairability

The bonnet is easily removed for internal parts inspection and/or replacement without removing the valve from the line. This design simplicity permits fast and easy service without the need for special tools.

3. Rising stem design

The mud valve uses a rising stem design that isolates and protects the threads from the line medium. The rising stem also indicates gate position. On 3" (80 mm) and larger valves, a clear position indicator shell allows the operator to easily determine whether the valve is open or closed. The indicator shell also helps to protect the stem threads from the elements.

4. Locking seat alignment

The seat assembly is engineered with a metal lock shell that aligns the seat in the bottom of the valve. This design ensures accurate seat alignment with reduced resistance to flow.

5. Flow cleansed design

The body cavity area is designed to allow continuous flushing by the fluid flow. This action prevents the valve from sanding up, even in standpipe installations

6. "T" slot stem design

A slab gate with a "T" slot stem connection allows the gate to float to the seat, providing a tighter pressure-responsive seal.

7. Body wear rings

Surface hardened alloy body wear rings back up both sides of the seat. These rings extend the service life of the valve by absorbing erosive wear that can cause damage to the body around the seat bore area.

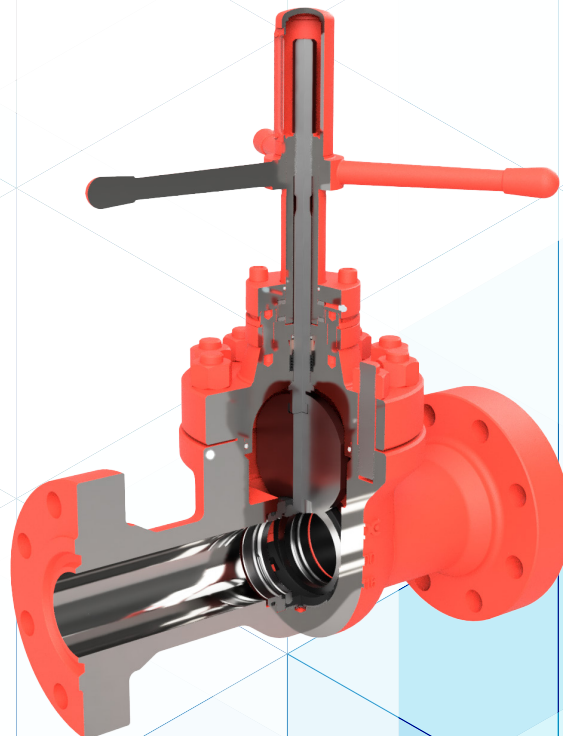

Dimensions, Materials, and Parts List:

Series GA gate valves—5,000-psi WP

2-in [50-mm] seat port

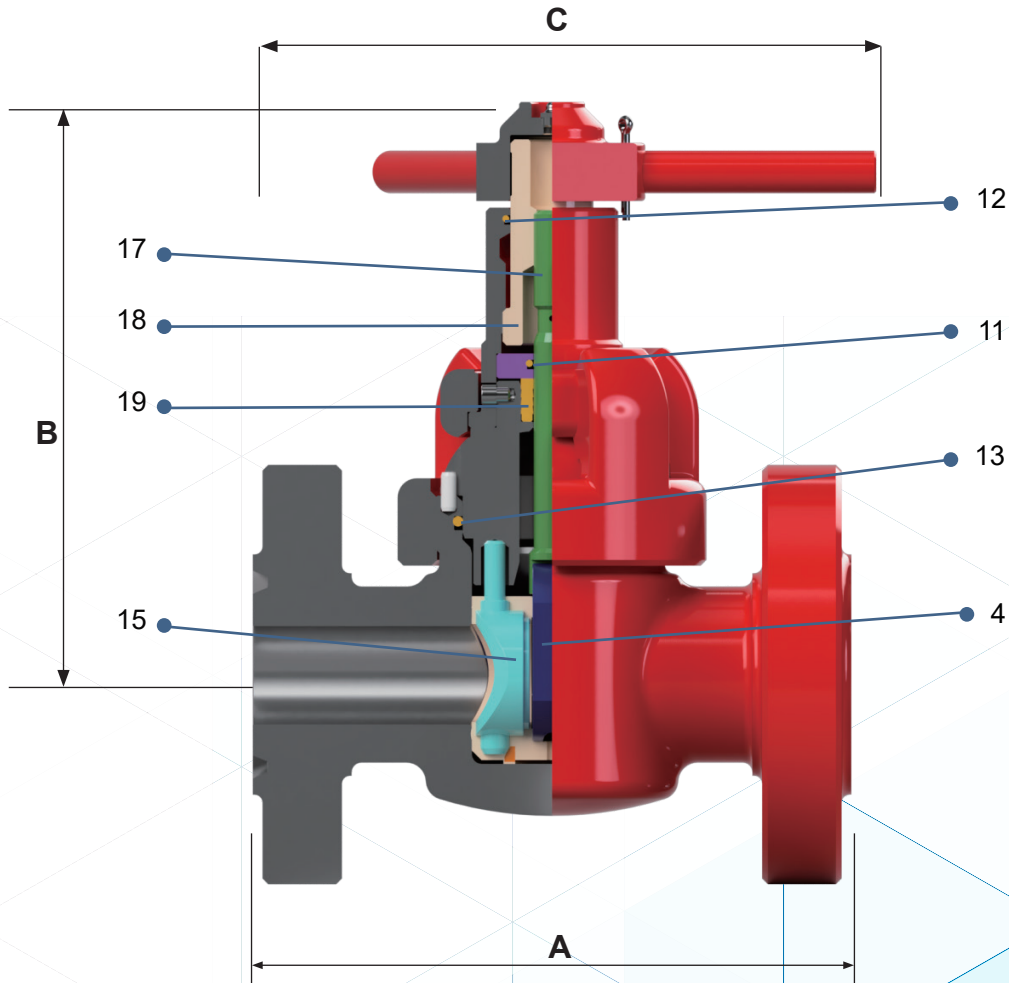

Dimensional Data and Weights

Dimension	Valve Seat Port Size for 5,000-psi WP: 2 in [50 mm]	
A, length, in [mm]	Weld end	9.00 [229]
	Flanged end, API length	12.12 [308]
For flanged ends	API ring number	R-24
	Flange ID, in [mm]	2.00 [51]
	Flange OD, in [mm]	8.50 [216]
	Flange bolts, amount, in [mm]	8: 7/8 [26]
	Weld OD	2.375 [60.3]
For Weld pipe size, in [mm]	Weld ID	Sch.40 2.067 [52.48]
		Sch.80 1.939 [49.22]
		Sch.160 1.687 [42.82]
		XXH 1.503 [38.16]
Weight, lbm [kg]	Weld end	61.73 [28]
	Flanged end	106.04 [48.1]
Number of handle turns from open to closed		10
B, height, center to top (open), in [mm]		13 [330]
C, handle diameter, in [mm]		13.1 [334]

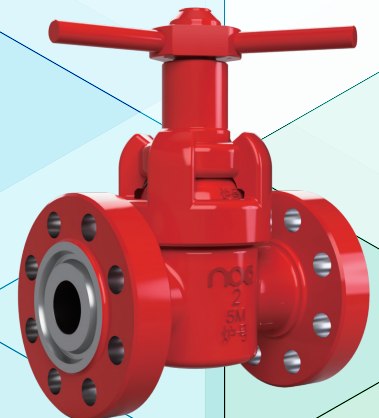

Parts List:

Major repair kit	Minor repair kit	Key No.	Qty.	Description	Valve Seat Port Size for 5,000-psi WP: 2 in [50 mm]
		1	1	Body	AISI 4130
		2	1	Bonnet	AISI 4130
		3	1	Coupling	AISI 4130
■	●	4	1	Gate	41XX with electroless nickel plating (ENP) ASTM A351 Gr. CF8M
		5	2	Handle	Carbon Steel
		6	1	Housing	AISI 4130
		7	1	Index pin	ASTM A240 304
		8	1	Lock handle	Carbon Steel
		9	1	Lock screw	Carbon Steel
		10	1	Lubricating nipple	ASTM A240 304
■		11	1	O-ring, secondary seal	HNBR
■		12	1	O-ring, housing seal	HNBR
■	●	13	1	O-ring, bonnet seal	HNBR FKM
		14	1	Retainer	Low alloy steel
■	●	15	1	Seat assembly	ASTM A351 Gr. CF8M and HNBR ASTM A351 Gr. CF8M and FKM
		16	3	Split pin	ASTM A240 304
■		17	1	Stem	316 SS
■		18	1	Stem screw	Low alloy steel
■		19	1	Stem seal assembly with bushing	HNBR and bronze PTFE and 316 SS FKM and bronze
		20	1	Handle housing	Carbon Steel

■ Major repair kit

● Minor repair kit

Dimensions, Materials, and Parts List:

Series GAM gate valves—7,500-psi WP

2-in [50-mm] seat port

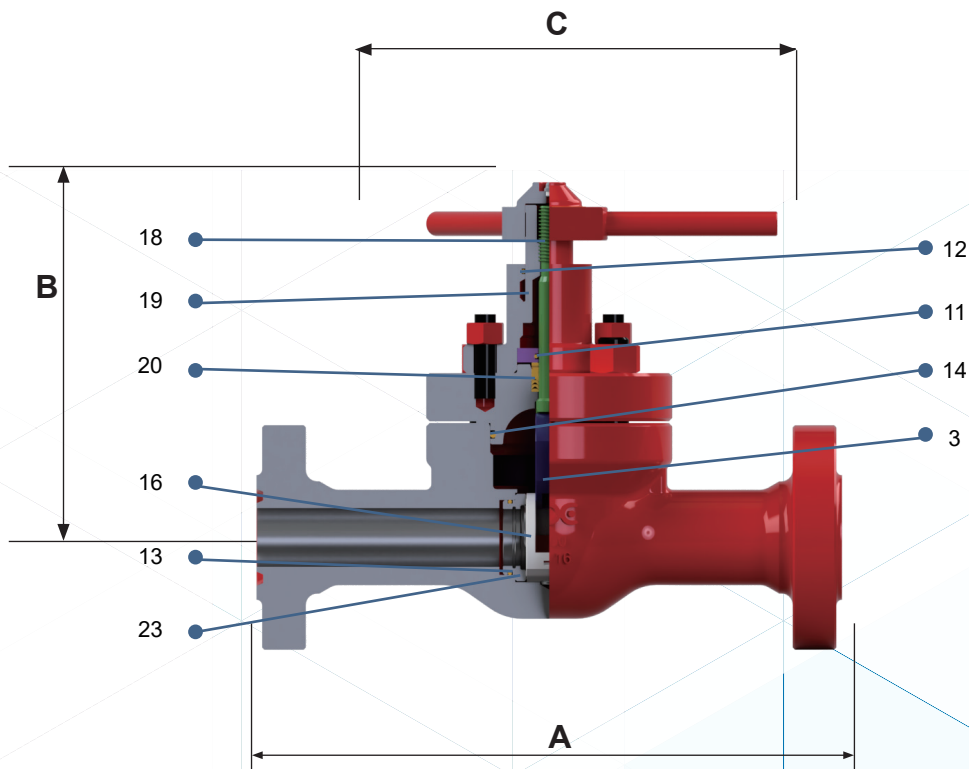

Dimensional Data and Weights

Dimension	Valve Seat Port Size for 7,500-psi WP: 2 in [50 mm]	
A, length, in [mm]	Weld end	9.00 [229]
	Flanged end, API length	20.50 [521]
	Hammer union end	15.74 [400]
For flanged ends	API ring number	BX-152
	Flange ID, in [mm]	2.06 [52.4]
	Flange OD, in [mm]	7.88 [200]
	Flange bolts, amount; in [mm]	8; 3/4 [23]
For Weld pipe size, in [mm]	Weld OD	2.375 [60.3]
	Weld ID	Sch. 40 2.067 [52.48]
		Sch. 80 1.939 [49.22]
		Sch. 160 1.687 [42.82]
		XXH 1.503 [38.16]
Weight, lbm [kg]	Weld end	92.6 [42]
	Flanged end	158.07 [71.7]
Number of handle turns from open to closed		8.9
B, height, center to top (open), in [mm]		12.60 [320]
C, handle diameter, in [mm]		15.98 [406]

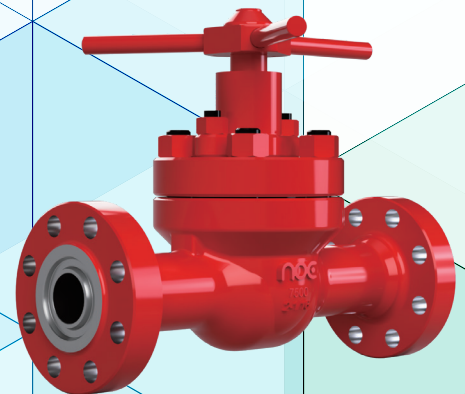

Parts List:

Major repair kit	Minor repair kit	Key No.	Qty.	Description	Valve Seat Port Size for 7,500-psi WP: 2 in [50 mm]
		1	1	Body	ASTM A487 Gr. 4 Class D
		2	1	Bonnet	AISI 4130
■	●	3	1	Gate	41XX with quench, polish, quench (QPQ) nitriding 410 SS with QPQ nitriding
		4	2	Handle	Carbon Steel
		5	1	Handle	Carbon Steel
		6	4	Heavy hex nut	ASTM A194 2H
		7	2	Heavy hex nut	ASTM A194 2H
		8	1	Housing	Carbon Steel
		9	1	Lock handle	Carbon Steel
		10	1	Lubricating nipple	ASTM A276 304
■		11	1	O-ring, secondary seal	HNBR FKM
■		12	1	O-ring, housing seal	HNBR
■	●	13	2	O-ring, wear ring seal	HNBR FKM
■	●	14	1	O-ring, bonnet seal	HNBR FKM
		15	1	Retainer	4130
■	●	16	1	Seat assembly	410 SS with QPQ nitriding and HNBR 410 SS with QPQ nitriding and FKM
		17	3	Split pin	ASTM A276 304
■		18	1	Stem	410 SS with QPQ nitriding
■		19	1	Stem nut	4130 with QPQ nitriding
■		20	1	Stem seal assembly with bushing	HNBR and bronze FKM and bronze
		21	4	Stud	ASTM A193 B7
		22	2	Stud	ASTM A193 B7
■	●	23	2	Wear ring	41XX with QPQ nitriding 410 SS
		24	1	Packing gland	AISI 4130

■ Major repair kit
● Minor repair kit

Dimensions, Materials, and Parts List:

Series GA gate valves—5,000-psi WP

3-in [80-mm] seat port

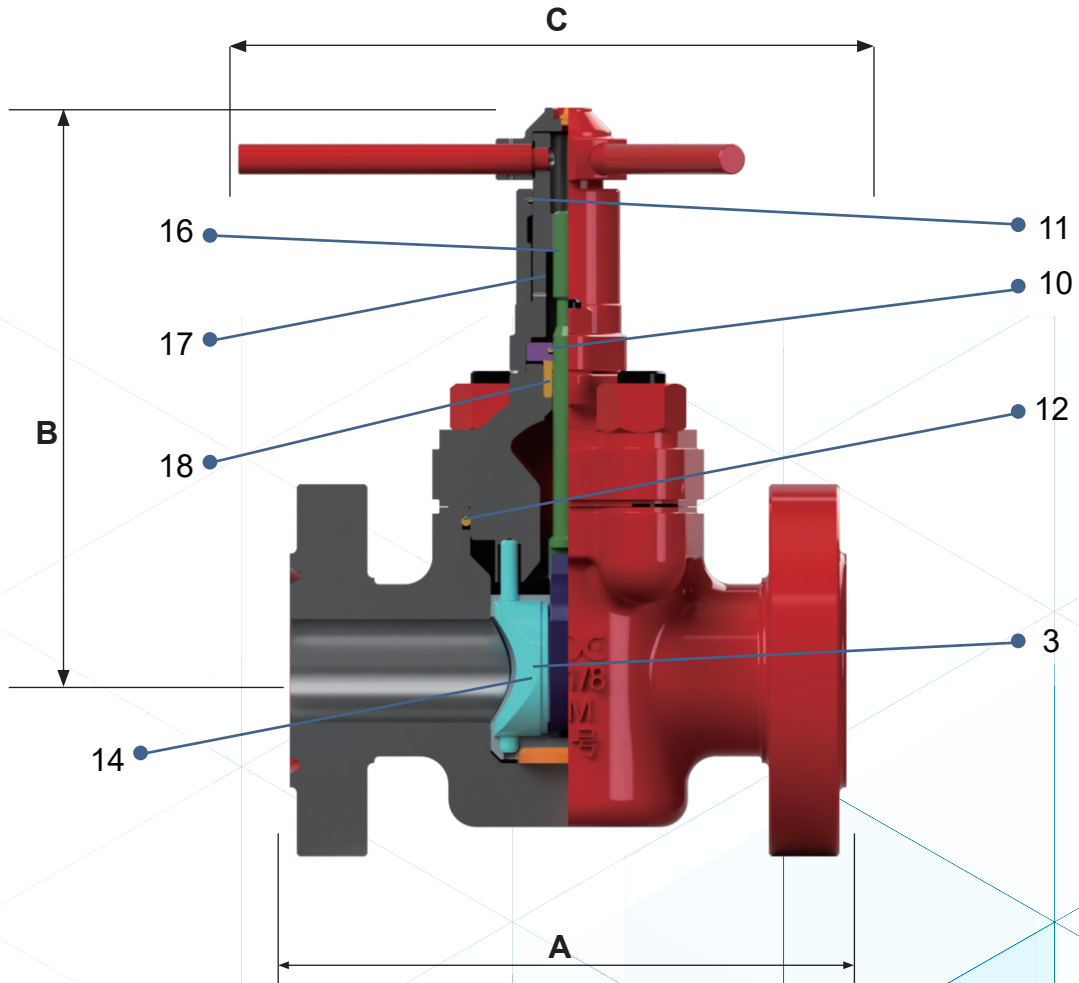

Dimensional Data and Weights

Dimension	Valve Seat Port Size for 5,000-psi WP: 3 in [80 mm]	
A, length, in [mm]	Weld end	11.00 [279]
	Flanged end, API length	15.67 [398]
For flanged ends	API ring number	R-35
	Flange ID, in [mm]	2.94 [74.7]
	Flange OD, in [mm]	10.50 [267]
	Flange bolts, amount, in [mm]	8; 1-1/8 [32]
For Weld pipe size, in [mm]	Weld OD	3.5 [88.9]
	Weld ID	Sch.40 3.068 [78.0]
		Sch.80 2.9 [73.5]
		Sch.160 2.624 [66.5]
		XXH 2.3 [58.5]
Weight, lbm [kg]	Weld end	165.35 [75]
	Flanged end	245.59 [111.4]
Number of handle turns from open to closed		10.7
B, height, center to top (open), in [mm]		18 [457]
C, handle diameter, in [mm]		18.6 [472]

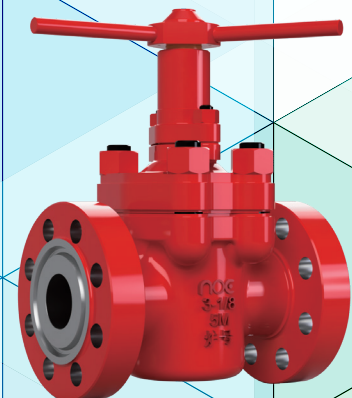

Parts List:

Major repair kit	Minor repair kit	Key No.	Qty.	Description	Valve Seat Port Size for 5,000-psi WP:3 in [80 mm]
		1	1	Body	AISI 4130
		2	1	Bonnet	AISI 4130
■	●	3	1	Gate	41XX with ENP ASTM A351 Gr. CF8M
		4	1	Handle	Carbon Steel
		5	4	Heavy hex nut	ASTM A194 2H
		6	2	Heavy hex nut	ASTM A194 2H
		7	1	Housing	AISI 4130
		8	1	Lock handle	Carbon Steel
		9	1	Lubricating nipple	ASTM A240 304
■		10	1	O-ring, secondary seal	HNBR
■		11	1	O-ring, housing seal	HNBR
■	●	12	1	O-ring, bonnet seal	HNBR FKM
		13	1	Retainer	Low alloy steel
■	●	14	1	Seat assembly	ASTM A351 Gr. CF8M and HNBR ASTM A351 Gr. CF8M and FKM
		15	1	Split pin, 3/16 × 13/4	Steel
■		16	1	Stem	316 SS
■		17	1	Stem screw	Low alloy steel
■		18	1	Stem seal assembly with bushing	HNBR and bronze PTFE and 316 SS FKM and bronze
		19	2	Stud	ASTM A193 B7
		20	4	Stud	ASTM A193 B7
		21	1	Handle housing	Carbon Steel

- Major repair kit
- Minor repair kit

Dimensions, Materials, and Parts List:

Series GAM gate valves—7,500-psi WP

3-in [80-mm] seat port

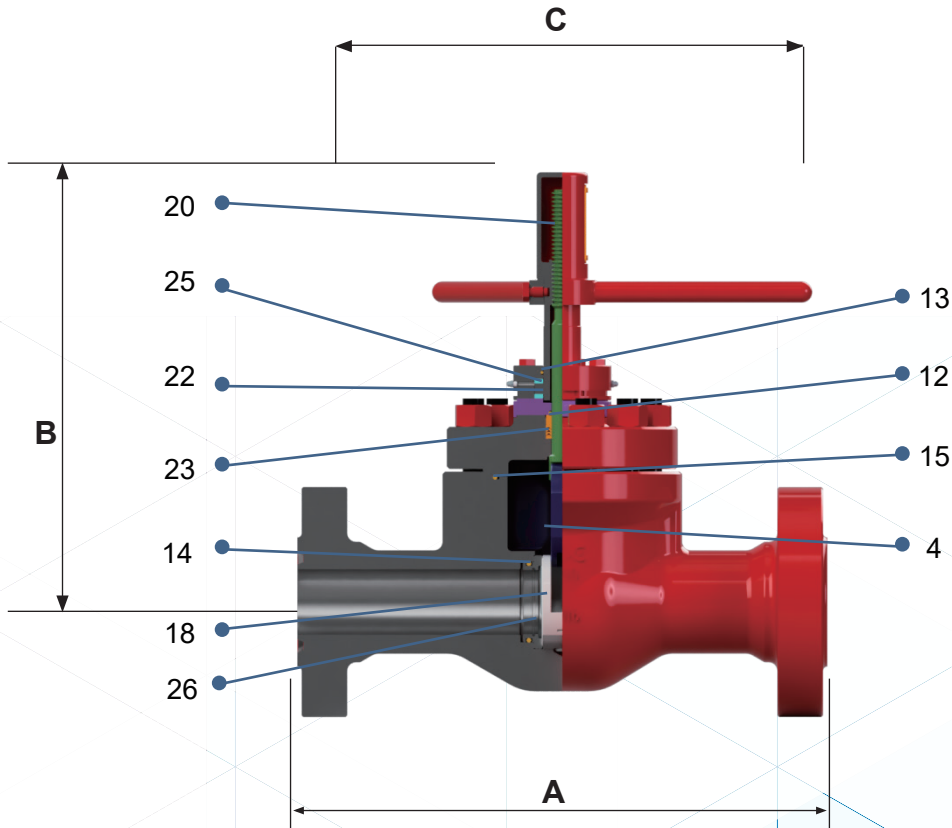

Dimensional Data and Weights

Dimension	Valve Seat Port Size for 7,500-psi WP: 3 in [80 mm]	
A, length, in [mm]	Weld end	13.00 [330]
	Flanged end, API length	24.38 [619]
	Hammer union end	
For flanged ends	API ring number	BX-154
	Flange ID, in [mm]	3.06 [77.8]
	Flange OD, in [mm]	10.62 [270]
	Flange bolts, amount; in [mm]	8; 1 [29]
For Weld pipe size, in [mm]	Weld OD	3.5 [88.9]
	Weld ID	Sch.40 3.068 [78.0]
		Sch.80 2.9 [73.5]
		Sch.160 2.624 [66.5]
		XXH 2.3 [58.5]
Weight, lbm [kg]	Weld end	209.44 [95]
	Flanged end	349.21 [158.4]
Number of handle turns from open to closed		16.2
B, height, center to top (open), in [mm]		19.80 [503]
C, handle diameter, in [mm]		23 [584]



Parts List:

Major repair kit	Minor repair kit	Key No.	Qty.	Description	Valve Seat Port Size for 7,500-psi WP: 3 in [80 mm]
		1	1	Body	AISI 4130
		2	1	Bonnet	AISI 4130
		3	4	Capscrew socket head	ASTM A574 Alloy Steel
■	●	4	1	Gate	41XX with QPQ nitriding 410 SS with QPQ nitriding
		5	4	Hex head bolt	ASTM A193 B7
		6	1	Handwheel	Carbon Steel
		7	1	Handle screw	Carbon Steel
		8	12	Heavy hex nut	ASTM A194 2H
		9	1	Housing	AISI 4130
		10	4	Hex head bolt	ASTM A193 B7
		11	2	Lubricating nipple	ASTM A276 304
■		12	1	O-ring, secondary seal	HNBR FKM
■		13	1	O-ring, housing seal	Buna-N
■	●	14	2	O-ring, wear ring seal	HNBR FKM
■	●	15	1	O-ring, bonnet seal	HNBR FKM
		16	1	Packing gland	AISI 4130
		17	1	Retainer	AISI 4130
■	●	18	1	Seat assembly	410 SS with QPQ nitriding and HNBR 410 SS with QPQ nitriding and FKM
		19	1	Sight tube	Clear acrylic
■		20	1	Stem	410 SS with QPQ nitriding
		21	1	Stem cap	Carbon Steel
■		22	1	Stem nut	AISI 4130 with QPQ nitriding
■		23	1	Stem seal assembly with bushing	HNBR and bronze FKM and bronze
		24	12	Stud	ASTM A193 Gr. B7
■		25	2	Thrust needle roller bearing	Hardened steel
■	●	26	2	Wear ring	41XX with QPQ nitriding 410 SS

- Major repair kit
- Minor repair kit

Dimensions, Materials, and Parts List:

Series GA gate valves—5,000-psi WP

4-in [100-mm] seat port

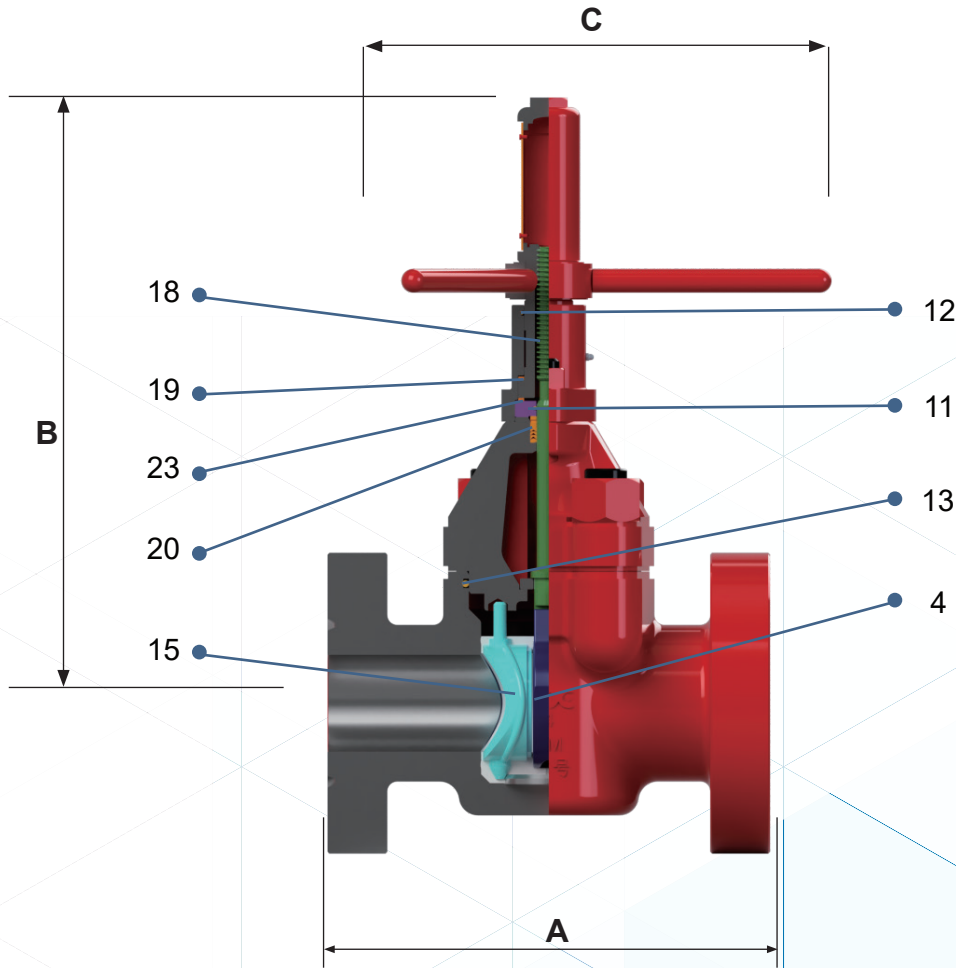

Dimensional Data and Weights

Dimension	Valve Seat Port Size for 5,000-psi WP: 4 in [100 mm]	
A, length, in [mm]	Weld end	13.00 [330]
	Flanged end, API length	18.00 [457]
For flanged ends	API ring number	R-39
	Flange ID, in [mm]	4.00 [100]
	Flange OD, in [mm]	12.25 [311]
	Flange bolts, amount; in [mm]	8-1/4 [35]
For Weld pipe size, in [mm]	Weld OD	4.5 [114.3]
	Weld ID	Sch.40 4.026 [102.0]
		Sch.80 3.826 [97.0]
		Sch.160 3.438 [87.5]
		XXH 3.152 [80.0]
Weight, lbm [kg]	Weld end	244.7 [111]
	Flanged end	390.2 [177]
Number of handle turns from open to closed		23.7
B, height, center to top (open), in [mm]		24.63 [625.5]
C, handle diameter, in [mm]		23.00 [584]



Parts List:

Major repair kit	Minor repair kit	Key No.	Qty.	Description	Valve Seat Port Size for 5,000-psi WP: 4 in [100 mm]
		1	1	Body	AISI 4130
		2	1	Bonnet	AISI 4130
		3	1	Downstop ring	Low alloy steel
■	●	4	1	Gate	41XX with ENP 410 SS with QPQ nitriding
		5	1	Handwheel	Carbon Steel
		6	4	Heavy hex nut	ASTM A194 2H
		7	2	Heavy hex nut	ASTM A194 2H
		8	1	Housing	AISI 4130
■		9	1	Key	Carbon Steel
		10	1	Lubricating nipple	Steel
■		11	1	O-ring, secondary seal	HNBR
■		12	1	O-ring, housing seal	HNBR
■	●	13	1	O-ring, bonnet seal	HNBR FKM
		14	1	Retainer	Carbon Steel
■	●	15	1	Seat assembly	ASTM A351 Gr. CF8M and HNBR ASTM A351 Gr. CF8M and FKM
		16	1	Sight tube	Clear acrylic
		17	1	Stem cap	Low alloy steel
■		18	1	Stem	410 SS
■		19	1	Stem screw	Low alloy steel
■		20	1	Stem seal assembly with bushing	HNBR and bronze FKM and bronze
		21	2	Stud	ASTM A193 B7
		22	4	Stud	ASTM A193 B7
■		23	2	Thrust washer	Teflon and phenolic material
		24	1	Packing gland	Low alloy steel

- Major repair kit
- Minor repair kit

Dimensions, Materials, and Parts List:

Series GAM gate valves—7,500-psi WP

4-in [100-mm] seat port

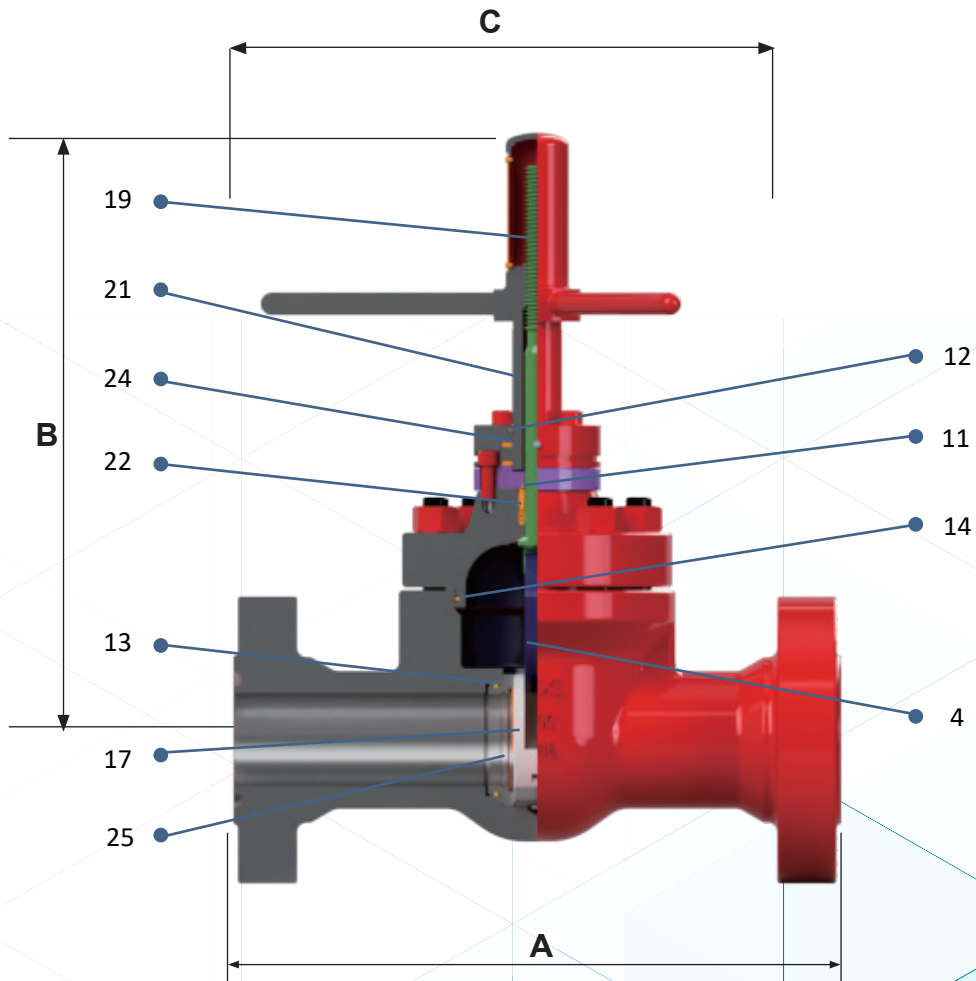

Dimensional Data and Weights

Dimension	Valve Seat Port Size for 7,500-psi WP: 4 in [100 mm]	
A, length, in [mm]	Weld end	16.00 [406]
	Flanged end, API length	26.38 [670]
	Hammer union end	
For flanged ends	API ring number	BX-155
	Flange ID, in [mm]	4.06 [103.2]
	Flange OD, in [mm]	12.44 [316]
	Flange bolts, amount, in [mm]	8; 1-1/8 [32]
	Weld ID	4.5 [114.3]
For Weld pipe size, in [mm]	Sch.40	4.026 [102.0]
	Sch.80	3.826 [97.0]
	Sch.160	3.438 [87.5]
	XXH	3.152 [80.0]
Weight, lbm [kg]	Weld end	288.81 [131]
	Flanged end	474.21 [215.1]
Number of handle turns from open to closed		
21.7		
B, height, center to top (open), in [mm]		
26.33 [669]		
C, handle diameter, in [mm]		
24 [610]		



Parts List:

Major repair kit	Minor repair kit	Key No.	Qty.	Description	Valve Seat Port Size for 7,500-psi WP: 4 in [100mm]
		1	1	Body	AISI 4130
		2	1	Bonnet	AISI 4130
		3	4	Capscrew socket head	ASTM A193 B7
■	●	4	1	Gate	41XX with QPQ nitriding 410 SS with QPQ nitriding
		5	1	Handwheel	Carbon Steel
		6	1	Handle screw	Carbon Steel
		7	10	Heavy hex nut	ASTM A194 2H
		8	4	Hex head bolt	ASTM A193 B7
		9	1	Housing	AISI 4130
		10	2	Lubricating nipple	ASTM A276 304
■		11	1	O-ring, secondary seal	HNBR FKM
■		12	1	O-ring, housing seal	Buna-N
■	●	13	2	O-ring, wear ring seal	HNBR FKM
■	●	14	1	O-ring, bonnet seal	HNBR FKM
		15	1	Packing gland	AISI 4130
		16	1	Retainer	AISI 4130
■	●	17	1	Seat assembly	410 SS with QPQ nitriding and HNBR 410 SS with QPQ nitriding and FKM
		18	1	Sight tube	Clear acrylic
■		19	1	Stem	410 SS with QPQ nitriding
		20	1	Stem cap	Carbon Steel
■		21	1	Stem screw	AISI 4130 with QPQ nitriding
■		22	1	Stem seal assembly with bushing	HNBR and bronze FKM and bronze
		23	10	Stud	ASTM A193 B7
■		24	2	Thrust needle roller bearing	Hardened steel
■	●	25	2	Wear ring	41XX with QPQ nitriding 410 SS

- Major repair kit
- Minor repair kit